

FEATURES

- Qualified for Automotive Applications
- Customer-Specific Configuration Control Can Be Supported Along With Major-Change Approval
- Specified Break-Before-Make Switching
- Low ON-State Resistance (15 Ω)
- Control Inputs Are 5-V Tolerant
- Low Charge Injection
- Excellent ON-Resistance Matching
- Low Total Harmonic Distortion
- 1.8-V to 5.5-V Single-Supply Operation

APPLICATIONS

- Sample-and-Hold Circuits
- Battery-Powered Equipment
- Audio and Video Signal Routing
- Communication Circuits

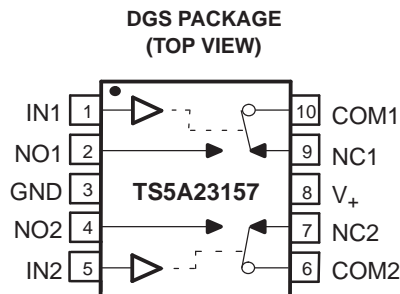

DESCRIPTION

The TS5A23157 is a dual, single-pole, double-throw (SPDT) analog switch designed to operate from 1.65 V to 5.5 V. This device can handle both digital and analog signals. Signals up to 5.5 V (peak) can be transmitted in either direction.

ORDERING INFORMATION

T _A	PACKAGE		ORDERABLE PART NUMBER	TOP-SIDE MARKING
–40°C to 105°C	VSSOP (MSOP-10) – DGS	Tape and reel	TS5A23157TDGSRQ1	JBR

FUNCTION TABLE

INPUT IN	NC TO COM, COM TO NC	NO TO COM, COM TO NO
L	ON	OFF
H	OFF	ON

SUMMARY OF CHARACTERISTICS

Configuration	2:1 Multiplexer/ Demultiplexer (2 × SPDT)
Number of channels	2
r _{on}	15 Ω
Δr _{on}	0.15 Ω
r _{on(flat)}	4 Ω
t _{ON} /t _{OFF}	8.7 ns/6.8 ns
t _{BBM}	0.5 ns
Charge injection	7 pC
Bandwidth	220 MHz
OFF isolation	–65 dB at 10 MHz
Crosstalk	–66 dB at 10 MHz
Total harmonic distortion	0.01%
I _{COM(off)} /I _{NC(OFF)}	±1 μA
Package option	10-pin DGS



Please be aware that an important notice concerning availability, standard warranty, and use in critical applications of Texas Instruments semiconductor products and disclaimers thereto appears at the end of this data sheet.

TS5A23157-Q1

DUAL 15-Ω SPDT ANALOG SWITCH

SCDS252–JULY 2007

Absolute Maximum Ratings⁽¹⁾

over operating free-air temperature range (unless otherwise noted)

			MIN	MAX	UNIT
V ₊	Supply voltage range ⁽²⁾		-0.5	6.5	V
V _{NC} V _{NO} V _{COM}	Analog voltage range ⁽²⁾⁽³⁾⁽⁴⁾		-0.5	V ₊ + 0.5	V
I _{I/O} K	Analog port diode current	V _{NC} , V _{NO} , V _{COM} < 0 or V _{NC} , V _{NO} , V _{COM} > V ₊		±50	mA
I _{NC} I _{NO} I _{COM}	On-state switch current	V _{NC} , V _{NO} , V _{COM} = 0 to V ₊		±50	mA
V _{IN}	Digital input voltage range ⁽²⁾⁽³⁾		-0.5	6.5	V
I _{IK}	Digital input clamp current	V _{IN} < 0		-50	mA
	Continuous current through V ₊ or GND			±100	mA
θ _{JA}	Package thermal impedance ⁽⁵⁾			165.36	°C/W
T _{stg}	Storage temperature range		-65	150	°C
ESD	Electrostatic discharge rating	Human-body model		2	kV
		Charged-device model		1	kV
		Machine model		200	V

(1) Stresses beyond those listed under "absolute maximum ratings" may cause permanent damage to the device. These are stress ratings only, and functional operation of the device at these or any other conditions beyond those indicated under "recommended operating conditions" is not implied. Exposure to absolute-maximum-rated conditions for extended periods may affect device reliability.

(2) All voltages are with respect to ground, unless otherwise specified.

(3) The input and output voltage ratings may be exceeded if the input and output clamp-current ratings are observed.

(4) This value is limited to 5.5 V maximum.

(5) The package thermal impedance is calculated in accordance with JESD 51-7.

Electrical Characteristics for 5-V Supply

$V_+ = 4.5\text{ V to }5.5\text{ V}$, $T_A = -40^\circ\text{C to }105^\circ\text{C}$ (unless otherwise noted)

PARAMETER	SYMBOL	TEST CONDITIONS	T_A	V_+	MIN	TYP ⁽¹⁾	MAX	UNIT
Analog Switch								
Analog signal range	V_{COM}, V_{NO}, V_{NC}				0		V_+	V
ON-state resistance	r_{on}	$0 \leq V_{NO} \text{ or } V_{NC} \leq V_+$, $I_{COM} = -30\text{ mA}$, Switch ON, See Figure 6	Full	4.5 V			15	Ω
ON-state resistance match between channels	Δr_{on}	$V_{NO} \text{ or } V_{NC} = 3.15\text{ V}$, $I_{COM} = -30\text{ mA}$, Switch ON, See Figure 6	25°C	4.5 V		0.15		Ω
ON-state resistance flatness	$r_{on(flat)}$	$0 \leq V_{NO} \text{ or } V_{NC} \leq V_+$, $I_{COM} = -30\text{ mA}$, Switch ON, See Figure 6	25°C	4.5 V		4		Ω
NC, NO OFF leakage current	$I_{NC(OFF)}, I_{NO(OFF)}$	$V_{NC} \text{ or } V_{NO} = 0 \text{ to } V_+$, $V_{COM} = 0 \text{ to } V_+$, Switch OFF, See Figure 7	25°C	5.5 V	-1	0.05	1	μA
			Full		-1		1	
NC, NO ON leakage current	$I_{NC(ON)}, I_{NO(ON)}$	$V_{NC} \text{ or } V_{NO} = 0 \text{ to } V_+$, $V_{COM} = \text{Open}$, Switch ON, See Figure 7	25°C	5.5 V	-0.1		0.1	μA
			Full		-1		1	
COM ON leakage current	$I_{COM(ON)}$	$V_{NC} \text{ or } V_{NO} = \text{Open}$, $V_{COM} = 0 \text{ to } V_+$, Switch ON, See Figure 7	25°C	5.5 V	-0.1		0.1	μA
			Full		-1		1	
Digital Inputs (IN1, IN2)⁽²⁾								
Input logic high	V_{IH}		Full		$V_+ \times 0.7$			V
Input logic low	V_{IL}		Full		$V_+ \times 0.3$			V
Input leakage current	I_{IH}, I_{IL}	$V_{IN} = 5.5\text{ V or }0$	25°C	5.5 V	-1	0.05	1	μA
			Full		-1		1	

(1) $T_A = 25^\circ\text{C}$

(2) All unused digital inputs of the device must be held at V_+ or GND to ensure proper device operation. Refer to the TI application report, *Implications of Slow or Floating CMOS Inputs*, literature number SCBA004.

TS5A23157-Q1

DUAL 15-Ω SPDT ANALOG SWITCH

SCDS252–JULY 2007

Electrical Characteristics for 5-V Supply (continued)

$V_+ = 4.5\text{ V to }5.5\text{ V}$, $T_A = -40^\circ\text{C to }105^\circ\text{C}$ (unless otherwise noted)

PARAMETER	SYMBOL	TEST CONDITIONS	T_A	V_+	MIN	TYP ⁽¹⁾	MAX	UNIT	
Dynamic									
Turn-on time	t_{ON}	$V_{NC} = \text{GND}$ and $V_{NO} = V_+$, or $V_{NC} = V_+$ and $V_{NO} = \text{GND}$, $R_L = 500\ \Omega$, $C_L = 50\ \text{pF}$, See Figure 9	Full	4.5 V to 5.5 V	1.2		8.7	ns	
Turn-off time	t_{OFF}	$V_{NC} = \text{GND}$ and $V_{NO} = V_+$, or $V_{NC} = V_+$ and $V_{NO} = \text{GND}$, $R_L = 500\ \Omega$, $C_L = 50\ \text{pF}$, See Figure 9	Full	4.5 V to 5.5 V	0.5		6.8	ns	
Break-before-make time	t_{BBM}	$V_{NC} = V_{NO} = V_+/2$, $R_L = 50\ \Omega$, $C_L = 35\ \text{pF}$, See Figure 10	25°C	4.5 V to 5.5 V	0.5			ns	
Charge injection	Q_C	$V_{NC} = V_{NO} = V_+/2$, $R_L = 50\ \Omega$, See Figure 14	25°C	5 V		7		pC	
NC, NO OFF capacitance	$C_{NC(OFF)}$, $C_{NO(OFF)}$	V_{NC} or $V_{NO} = V_+$ or GND, Switch OFF, See Figure 8	25°C	5 V		5.5		pF	
NC, NO ON capacitance	$C_{NC(ON)}$, $C_{NO(ON)}$	V_{NC} or $V_{NO} = V_+$ or GND, Switch ON, See Figure 8	25°C	5 V		17.5		pF	
COM ON capacitance	$C_{COM(ON)}$	$V_{COM} = V_+$ or GND, Switch ON, See Figure 8	25°C	5 V		17.5		pF	
Digital input capacitance	C_{IN}	$V_{IN} = V_+$ or GND, See Figure 8	25°C	5 V		2.8		pF	
Bandwidth	BW	$R_L = 50\ \Omega$, Switch ON, See Figure 11	25°C	4.5 V		220		MHz	
OFF isolation	O_{ISO}	$R_L = 50\ \Omega$, $f = 10\ \text{MHz}$, Switch OFF, See Figure 12	25°C	4.5 V		-65		dB	
Crosstalk	X_{TALK}	$R_L = 50\ \Omega$, $f = 10\ \text{MHz}$, Switch ON, See Figure 13	25°C	4.5 V		-66		dB	
Total harmonic distortion	THD	$R_L = 600\ \Omega$, $C_L = 50\ \text{pF}$, $f = 600\ \text{Hz to }20\ \text{kHz}$, See Figure 15	25°C	4.5 V		0.01		%	
Supply									
Positive supply current	I_+	$V_{IN} = V_+$ or GND, Switch ON or OFF	25°C	5.5 V				1	μA
			Full					10	
Change in supply current	ΔI_+	$V_{IN} = V_+ - 0.6\ \text{V}$	Full	5.5 V				500	μA

Electrical Characteristics for 3.3-V Supply

$V_+ = 3\text{ V to }3.6\text{ V}$, $T_A = -40^\circ\text{C to }105^\circ\text{C}$ (unless otherwise noted)

PARAMETER	SYMBOL	TEST CONDITIONS	T_A	V_+	MIN	TYP ⁽¹⁾	MAX	UNIT
Analog Switch								
Analog signal range	V_{COM}, V_{NO}, V_{NC}				0		V_+	V
ON-state resistance	r_{on}	$0 \leq V_{NO} \text{ or } V_{NC} \leq V_+$, $I_{COM} = -24\text{ mA}$, Switch ON, See Figure 6	Full	3 V			23	Ω
ON-state resistance match between channels	Δr_{on}	$V_{NO} \text{ or } V_{NC} = 2.1\text{ V}$, $I_{COM} = -24\text{ mA}$, Switch ON, See Figure 6	25°C	3 V		0.2		Ω
ON-state resistance flatness	$r_{on(flat)}$	$0 \leq V_{NO} \text{ or } V_{NC} \leq V_+$, $I_{COM} = -24\text{ mA}$, Switch ON, See Figure 6	25°C	3 V		9		Ω
NC, NO OFF leakage current	$I_{NC(OFF)}, I_{NO(OFF)}$	$V_{NC} \text{ or } V_{NO} = 0 \text{ to } V_+$, $V_{COM} = 0 \text{ to } V_+$, Switch OFF, See Figure 7	25°C	3.6 V	-1	0.05	1	μA
			Full		-1	1		
NC, NO ON leakage current	$I_{NC(ON)}, I_{NO(ON)}$	$V_{NC} \text{ or } V_{NO} = 0 \text{ to } V_+$, $V_{COM} = \text{Open}$, Switch ON, See Figure 7	25°C	3.6 V	-0.1		0.1	μA
			Full		-1	1		
COM ON leakage current	$I_{COM(ON)}$	$V_{NC} \text{ or } V_{NO} = \text{Open}$, $V_{COM} = 0 \text{ to } V_+$, Switch ON, See Figure 7	25°C	3.6 V	-0.1		0.1	μA
			Full		-1	1		
Digital Inputs (IN1, IN2)⁽²⁾								
Input logic high	V_{IH}		Full		$V_+ \times 0.7$			V
Input logic low	V_{IL}		Full		$V_+ \times 0.3$			V
Input leakage current	I_{IH}, I_{IL}	$V_{IN} = 5.5\text{ V or }0$	25°C	3.6 V	-1	0.05	1	μA
			Full		-1	1		
Dynamic								
Turn-on time	t_{ON}	$V_{NC} = \text{GND and } V_{NO} = V_+$, or $V_{NC} = V_+ \text{ and } V_{NO} = \text{GND}$, $R_L = 500\ \Omega$, $C_L = 50\text{ pF}$, See Figure 9	Full	3 V to 3.6 V	2.0		10.6	ns
Turn-off time	t_{OFF}	$V_{NC} = \text{GND and } V_{NO} = V_+$, or $V_{NC} = V_+ \text{ and } V_{NO} = \text{GND}$, $R_L = 500\ \Omega$, $C_L = 50\text{ pF}$, See Figure 9	Full	3 V to 3.6 V	1.0		8.3	ns
Break-before-make time	t_{BBM}	$V_{NC} = V_{NO} = V_+/2$, $R_L = 50\ \Omega$, $C_L = 35\text{ pF}$, See Figure 10	25°C	3 V to 3.6 V	0.5			ns
Charge injection	Q_C	$R_L = 50\ \Omega$, $C_L = 0.1\text{ nF}$, See Figure 14	25°C	3.3 V		3		pC
Bandwidth	BW	$R_L = 50\ \Omega$, Switch ON, See Figure 11	25°C	3 V		220		MHz
OFF isolation	O_{ISO}	$R_L = 50\ \Omega$, $f = 10\text{ MHz}$, Switch OFF, See Figure 12	25°C	3 V		-65		dB
Crosstalk	X_{TALK}	$R_L = 50\ \Omega$, $f = 10\text{ MHz}$, Switch ON, See Figure 13	25°C	3 V		-66		dB
Total harmonic distortion	THD	$R_L = 600\ \Omega$, $C_L = 50\text{ pF}$, $f = 600\text{ Hz to }20\text{ kHz}$, See Figure 15	25°C	3 V		0.015		%
Supply								
Positive supply current	I_+	$V_{IN} = V_+ \text{ or GND}$, Switch ON or OFF	25°C	3.6 V			1	μA
			Full				10	
Change in supply current	ΔI_+	$V_{IN} = V_+ - 0.6\text{ V}$	Full	3.6 V			500	μA

(1) $T_A = 25^\circ\text{C}$

(2) All unused digital inputs of the device must be held at V_+ or GND to ensure proper device operation. Refer to the TI application report, *Implications of Slow or Floating CMOS Inputs*, literature number SCBA004.

TS5A23157-Q1

DUAL 15-Ω SPDT ANALOG SWITCH

SCDS252–JULY 2007

Electrical Characteristics for 2.5-V Supply

$V_+ = 2.3 \text{ V to } 2.7 \text{ V}$, $T_A = -40^\circ\text{C to } 105^\circ\text{C}$ (unless otherwise noted)

PARAMETER	SYMBOL	TEST CONDITIONS	T_A	V_+	MIN	TYP ⁽¹⁾	MAX	UNIT
Analog Switch								
Analog signal range	V_{COM}, V_{NO}, V_{NC}				0		V_+	V
ON-state resistance	r_{on}	$0 \leq V_{NO} \text{ or } V_{NC} \leq V_+$, $I_{COM} = -8 \text{ mA}$, Switch ON, See Figure 6	Full	2.3 V			50	Ω
ON-state resistance match between channels	Δr_{on}	$V_{NO} \text{ or } V_{NC} = 1.6 \text{ V}$, $I_{COM} = -8 \text{ mA}$, Switch ON, See Figure 6	25°C	2.3 V		0.5		Ω
ON-state resistance flatness	$r_{on(flat)}$	$0 \leq V_{NO} \text{ or } V_{NC} \leq V_+$, $I_{COM} = -8 \text{ mA}$, Switch ON, See Figure 6	25°C	2.3 V		27		Ω
NC, NO OFF leakage current	$I_{NC(OFF)}, I_{NO(OFF)}$	$V_{NC} \text{ or } V_{NO} = 0 \text{ to } V_+$, $V_{COM} = 0 \text{ to } V_+$, Switch OFF, See Figure 7	25°C	2.7 V	-1	0.05	1	μA
			Full		-1		1	
NC, NO ON leakage current	$I_{NC(ON)}, I_{NO(ON)}$	$V_{NC} \text{ or } V_{NO} = 0 \text{ to } V_+$, $V_{COM} = \text{Open}$, Switch ON, See Figure 7	25°C	2.7 V	-0.1		0.1	μA
			Full		-1		1	
COM ON leakage current	$I_{COM(ON)}$	$V_{NC} \text{ or } V_{NO} = \text{Open}$, $V_{COM} = 0 \text{ to } V_+$, Switch ON, See Figure 7	25°C	2.7 V	-0.1		0.1	μA
			Full		-1		1	
Digital Inputs (IN1, IN2)⁽²⁾								
Input logic high	V_{IH}		Full		$V_+ \times 0.7$			V
Input logic low	V_{IL}		Full		$V_+ \times 0.3$			V
Input leakage current	I_{IH}, I_{IL}	$V_{IN} = 5.5 \text{ V or } 0$	25°C	2.7 V	-1	0.05	1	μA
			Full		-1		1	
Dynamic								
Turn-on time	t_{ON}	$V_{NC} = \text{GND and } V_{NO} = V_+$, or $V_{NC} = V_+ \text{ and } V_{NO} = \text{GND}$, $R_L = 500 \text{ } \Omega$, $C_L = 50 \text{ pF}$, See Figure 9	Full	2.3 V to 2.7 V	2.5		17	ns
Turn-off time	t_{OFF}	$V_{NC} = \text{GND and } V_{NO} = V_+$, or $V_{NC} = V_+ \text{ and } V_{NO} = \text{GND}$, $R_L = 500 \text{ } \Omega$, $C_L = 50 \text{ pF}$, See Figure 9	Full	2.3 V to 2.7 V	1.5		10.5	ns
Break-before-make time	t_{BBM}	$V_{NC} = V_{NO} = V_+/2$, $R_L = 50 \text{ } \Omega$, $C_L = 35 \text{ pF}$, See Figure 10	25°C	2.3 V to 2.7 V	0.5			ns
Bandwidth	BW	$R_L = 50 \text{ } \Omega$, Switch ON, See Figure 11	25°C	2.3 V		220		MHz
OFF isolation	O_{ISO}	$R_L = 50 \text{ } \Omega$, $f = 10 \text{ MHz}$, Switch OFF, See Figure 12	25°C	2.3 V		-65		dB
Crosstalk	X_{TALK}	$R_L = 50 \text{ } \Omega$, $f = 10 \text{ MHz}$, Switch ON, See Figure 13	25°C	2.3 V		-66		dB
Total harmonic distortion	THD	$R_L = 600 \text{ } \Omega$, $C_L = 50 \text{ pF}$, $f = 600 \text{ Hz to } 20 \text{ kHz}$, See Figure 15	25°C	2.3 V		0.025		%
Supply								
Positive supply current	I_+	$V_{IN} = V_+ \text{ or } \text{GND}$, Switch ON or OFF	25°C	2.7 V			1	μA
			Full				10	
Change in supply current	ΔI_+	$V_{IN} = V_+ - 0.6 \text{ V}$	Full	2.7 V			500	μA

(1) $T_A = 25^\circ\text{C}$

(2) All unused digital inputs of the device must be held at V_+ or GND to ensure proper device operation. Refer to the TI application report, *Implications of Slow or Floating CMOS Inputs*, literature number SCBA004.

Electrical Characteristics for 1.8-V Supply

$V_+ = 1.65\text{ V to }1.95\text{ V}$, $T_A = -40^\circ\text{C to }105^\circ\text{C}$ (unless otherwise noted)

PARAMETER	SYMBOL	TEST CONDITIONS	T_A	V_+	MIN	TYP ⁽¹⁾	MAX	UNIT
Analog Switch								
Analog signal range	V_{COM}, V_{NO}, V_{NC}				0		V_+	V
ON-state resistance	r_{on}	$0 \leq V_{NO} \text{ or } V_{NC} \leq V_+$, $I_{COM} = -4\text{ mA}$, Switch ON, See Figure 6	Full	1.65 V			160	Ω
ON-state resistance match between channels	Δr_{on}	$V_{NO} \text{ or } V_{NC} = 1.15\text{ V}$, $I_{COM} = -4\text{ mA}$, Switch ON, See Figure 6	25°C	1.65 V		1		Ω
ON-state resistance flatness	$r_{on(flat)}$	$0 \leq V_{NO} \text{ or } V_{NC} \leq V_+$, $I_{COM} = -4\text{ mA}$, Switch ON, See Figure 6	25°C	1.65 V		110		Ω
NC, NO OFF leakage current	$I_{NC(OFF)}, I_{NO(OFF)}$	$V_{NC} \text{ or } V_{NO} = 0 \text{ to } V_+$, $V_{COM} = 0 \text{ to } V_+$, Switch OFF, See Figure 7	25°C	1.95 V	-1	0.05	1	μA
			Full		-1		1	
NC, NO ON leakage current	$I_{NC(ON)}, I_{NO(ON)}$	$V_{NC} \text{ or } V_{NO} = 0 \text{ to } V_+$, $V_{COM} = \text{Open}$, Switch ON, See Figure 7	25°C	1.95 V	-0.1		0.1	μA
			Full		-1		1	
COM ON leakage current	$I_{COM(ON)}$	$V_{NC} \text{ or } V_{NO} = \text{Open}$, $V_{COM} = 0 \text{ to } V_+$, Switch ON, See Figure 7	25°C	1.95 V	-0.1		0.1	μA
			Full		-1		1	
Digital Inputs (IN1, IN2)⁽²⁾								
Input logic high	V_{IH}		Full		$V_+ \times 0.75$			V
Input logic low	V_{IL}		Full		$V_+ \times 0.25$			V
Input leakage current	I_{IH}, I_{IL}	$V_{IN} = 5.5\text{ V or }0$	25°C	1.95 V	-1	0.05	1	μA
			Full		-1		1	
Dynamic								
Turn-on time	t_{ON}	$V_{NC} = \text{GND and } V_{NO} = V_+$, or $V_{NC} = V_+ \text{ and } V_{NO} = \text{GND}$, $R_L = 500\ \Omega$, $C_L = 50\text{ pF}$, See Figure 9	Full	1.65 V to 1.95 V	5.5		27	ns
Turn-off time	t_{OFF}	$V_{NC} = \text{GND and } V_{NO} = V_+$, or $V_{NC} = V_+ \text{ and } V_{NO} = \text{GND}$, $R_L = 500\ \Omega$, $C_L = 50\text{ pF}$, See Figure 9	Full	1.65 V to 1.95 V	2		16	ns
Break-before-make time	t_{BBM}	$V_{NC} = V_{NO} = V_+/2$, $R_L = 50\ \Omega$, $C_L = 35\text{ pF}$, See Figure 10	25°C	1.65 V to 1.95 V	0.5			ns
Bandwidth	BW	$R_L = 50\ \Omega$, Switch ON, See Figure 11	25°C	1.8 V		220		MHz
OFF isolation	O_{ISO}	$R_L = 50\ \Omega$, $f = 10\text{ MHz}$, Switch OFF, See Figure 12	25°C	1.8 V		-60		dB
Crosstalk	X_{TALK}	$R_L = 50\ \Omega$, $f = 10\text{ MHz}$, Switch ON, See Figure 13	25°C	1.8 V		-66		dB
Total harmonic distortion	THD	$R_L = 600\ \Omega$, $C_L = 50\text{ pF}$, $f = 600\text{ Hz to }20\text{ kHz}$, See Figure 15	25°C	1.8 V		0.015		%
Supply								
Positive supply current	I_+	$V_{IN} = V_+ \text{ or GND}$, Switch ON or OFF	25°C	1.95 V			1	μA
			Full				10	
Change in supply current	ΔI_+	$V_{IN} = V_+ - 0.6\text{ V}$	Full	1.95 V			500	μA

(1) $T_A = 25^\circ\text{C}$

(2) All unused digital inputs of the device must be held at V_+ or GND to ensure proper device operation. Refer to the TI application report, *Implications of Slow or Floating CMOS Inputs*, literature number SCBA004.

TYPICAL CHARACTERISTICS

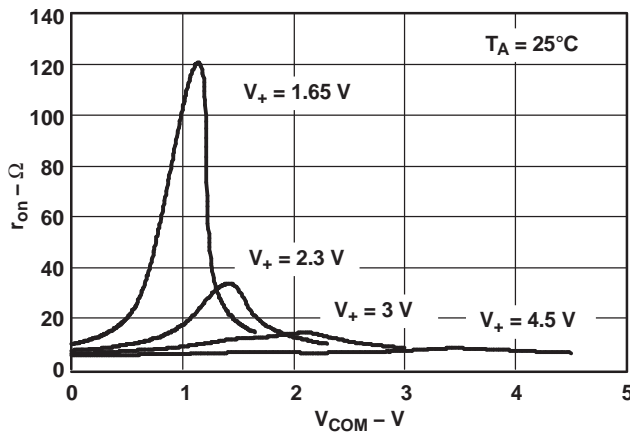

Figure 1. r_{on} vs V_{COM}

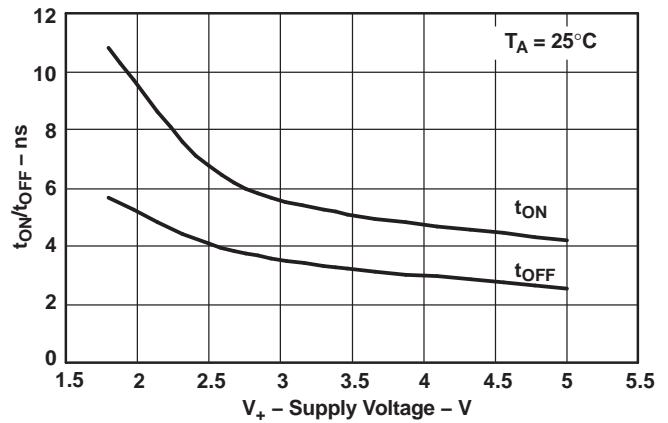

Figure 2. t_{ON} and t_{OFF} vs V_+

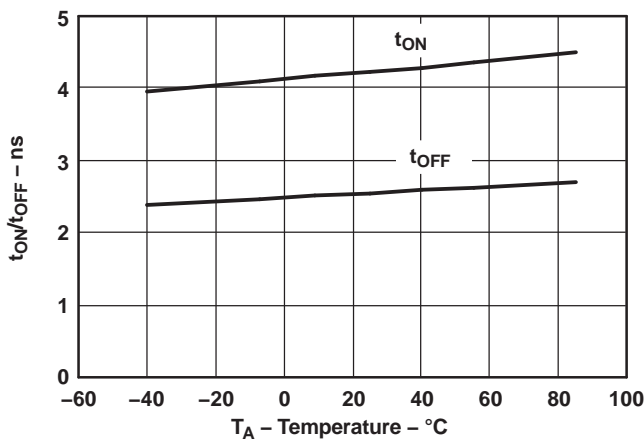

Figure 3. t_{ON} and t_{OFF} vs Temperature ($V_+ = 5 V$)

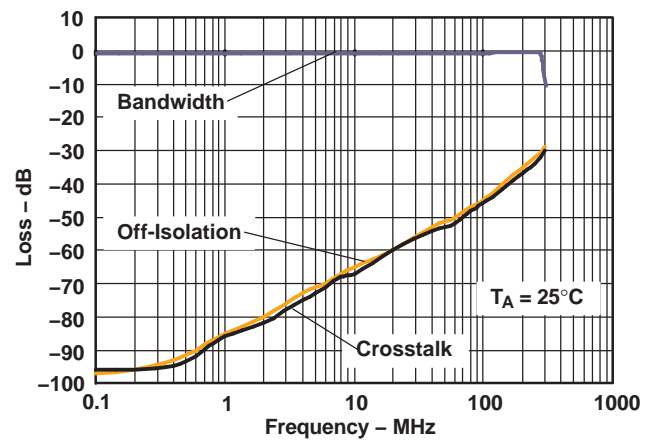

Figure 4. Frequency Response ($V_+ = 3 V$)

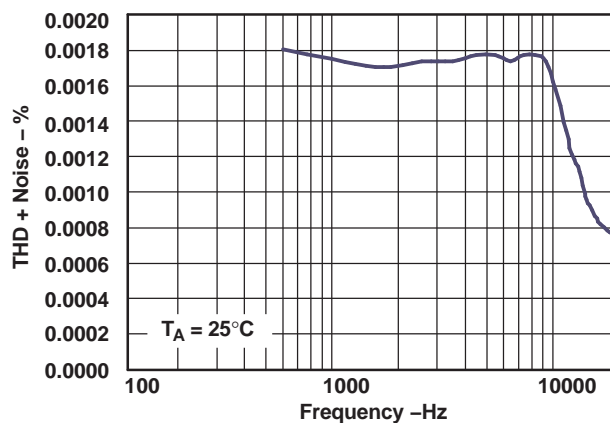

Figure 5. Total Harmonic Distortion (THD) vs Frequency ($V_+ = 3 V$)

PIN DESCRIPTION

PIN NO.	NAME	DESCRIPTION
1	IN1	Digital control to connect COM to NO or NC
2	NO1	Normally open
3	GND	Digital ground
4	NO2	Normally open
5	IN2	Digital control to connect COM to NO or NC
6	COM2	Common
7	NC2	Normally closed
8	V ₊	Power supply
9	NC1	Normally closed
10	COM1	Common

PARAMETER DESCRIPTION

SYMBOL	DESCRIPTION
V _{COM}	Voltage at COM
V _{NC}	Voltage at NC
V _{NO}	Voltage at NO
r _{on}	Resistance between COM and NC or COM and NO ports when the channel is ON
Δr _{on}	Difference of r _{on} between channels
r _{on(flat)}	Difference between the maximum and minimum value of r _{on} in a channel over the specified range of conditions
I _{NC(OFF)}	Leakage current measured at the NC port, with the corresponding channel (NC to COM) in the OFF state under worst-case input and output conditions
I _{NO(OFF)}	Leakage current measured at the NO port, with the corresponding channel (NO to COM) in the OFF state under worst-case input and output conditions
I _{NC(ON)}	Leakage current measured at the NC port, with the corresponding channel (NC to COM) in the ON state and the output (COM) being open
I _{NO(ON)}	Leakage current measured at the NO port, with the corresponding channel (NO to COM) in the ON state and the output (COM) being open
I _{COM(ON)}	Leakage current measured at the COM port, with the corresponding channel (NO to COM or NC to COM) in the ON state and the output (NC or NO) being open
V _{IH}	Minimum input voltage for logic high for the control input (IN)
V _{IL}	Minimum input voltage for logic low for the control input (IN)
V _{IN}	Voltage at IN
I _{IH} , I _{IL}	Leakage current measured at IN
t _{ON}	Turn-on time for the switch. This parameter is measured under the specified range of conditions and by the propagation delay between the digital control (IN) signal and analog outputs (COM/NC/NO) signal when the switch is turning ON.
t _{OFF}	Turn-off time for the switch. This parameter is measured under the specified range of conditions and by the propagation delay between the digital control (IN) signal and analog outputs (COM/NC/NO) signal when the switch is turning OFF.
t _{BBM}	Break-before-make time. This parameter is measured under the specified range of conditions and by the propagation delay between the output of two adjacent analog channels (NC and NO) when the control signal changes state.
Q _C	Charge injection is a measurement of unwanted signal coupling from the control (IN) input to the analog (NC, NO, or COM) output. This is measured in coulombs (C) and measured by the total charge induced due to switching of the control input. Charge injection, Q _C = C _L × ΔV _O , C _L is the load capacitance and ΔV _O is the change in analog output voltage.
C _{NC(OFF)}	Capacitance at the NC port when the corresponding channel (NC to COM) is OFF
C _{NO(OFF)}	Capacitance at the NO port when the corresponding channel (NC to COM) is OFF
C _{NC(ON)}	Capacitance at the NC port when the corresponding channel (NC to COM) is ON
C _{NO(ON)}	Capacitance at the NO port when the corresponding channel (NC to COM) is ON
C _{COM(ON)}	Capacitance at the COM port when the corresponding channel (COM to NC or COM to NO) is ON
C _{IN}	Capacitance of IN

TS5A23157-Q1

DUAL 15-Ω SPDT ANALOG SWITCH

SCDS252–JULY 2007

PARAMETER DESCRIPTION (continued)

SYMBOL	DESCRIPTION
O_{ISO}	OFF isolation of the switch is a measurement of OFF-state switch impedance. This is measured in dB in a specific frequency, with the corresponding channel (NC to COM or NO to COM) in the OFF state. OFF isolation, $O_{ISO} = 20 \text{ LOG} (V_{NC}/V_{COM})$ dB, V_{COM} is the input and V_{NC} is the output.
X_{TALK}	Crosstalk is a measurement of unwanted signal coupling from an ON channel to an OFF channel (NC to NO or NO to NC). This is measured at a specific frequency and in dB. Crosstalk, $X_{TALK} = 20 \text{ log} (V_{NC1}/V_{NO1})$, V_{NO1} is the input and V_{NC1} is the output.
BW	Bandwidth of the switch. This is the frequency where the gain of an ON channel is -3 dB below the dc gain. Gain is measured from the equation, $20 \text{ log} (V_{NC}/V_{COM})$ dB, where V_{NC} is the output and V_{COM} is the input.
I_+	Static power-supply current with the control (IN) pin at V_+ or GND
ΔI_+	This is the increase in I_+ for each control (IN) input that is at the specified voltage, rather than at V_+ or GND.

PARAMETER MEASUREMENT INFORMATION

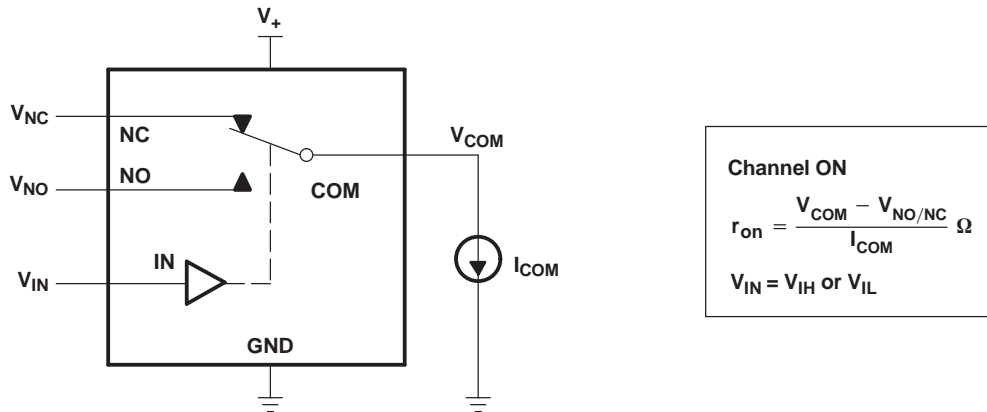

Figure 6. ON-State Resistance (R_{on})

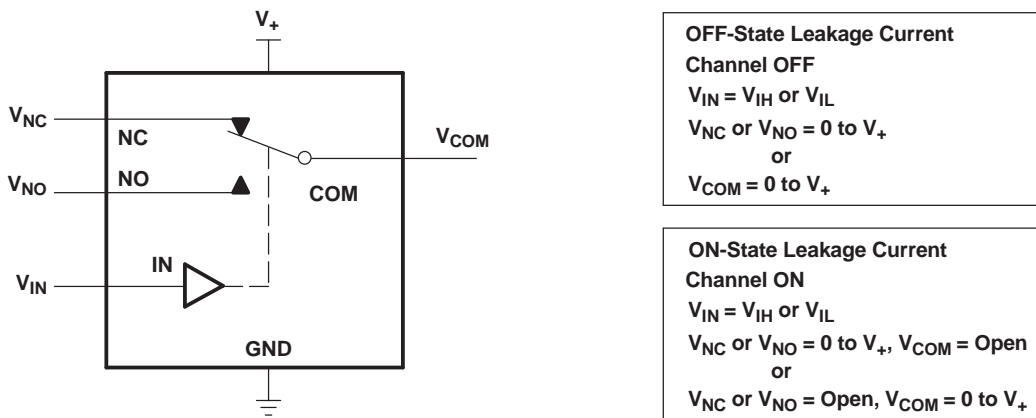

Figure 7. ON- and OFF-State Leakage Current ($I_{COM(ON)}$, $I_{NC(OFF)}$, $I_{NO(OFF)}$, $I_{NC(ON)}$, $I_{NO(ON)}$)

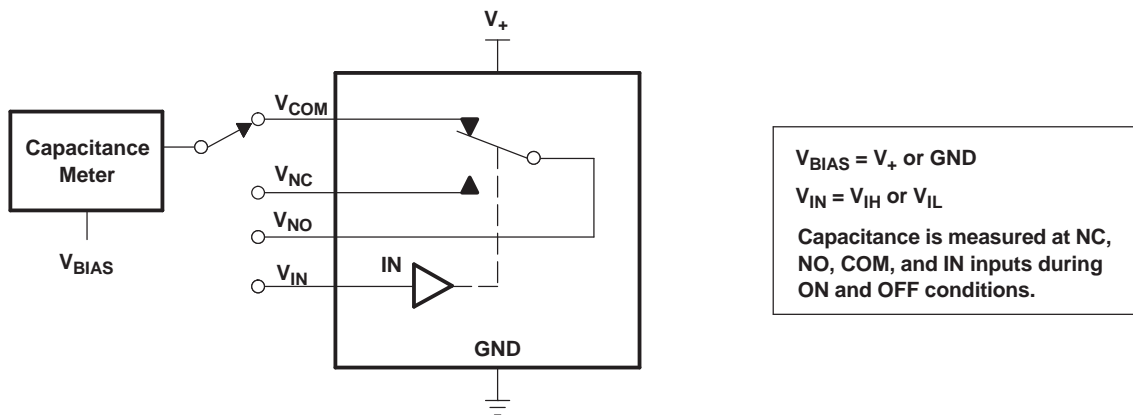

Figure 8. Capacitance (C_{IN} , $C_{COM(ON)}$, $C_{NC(OFF)}$, $C_{NO(OFF)}$, $C_{NC(ON)}$, $C_{NO(ON)}$)

PARAMETER MEASUREMENT INFORMATION (continued)

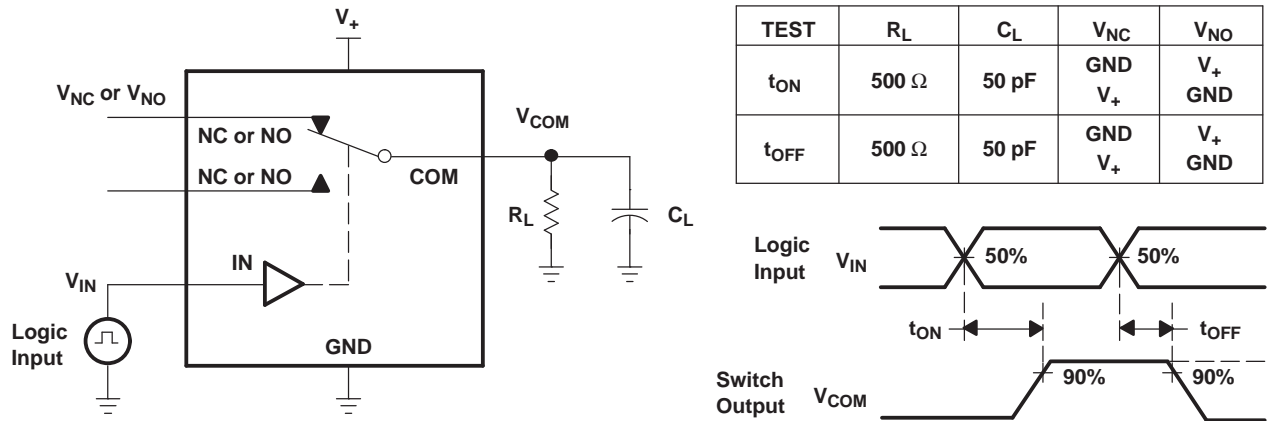

Figure 9. Turn-On Time (t_{ON}) and Turn-Off Time (t_{OFF})

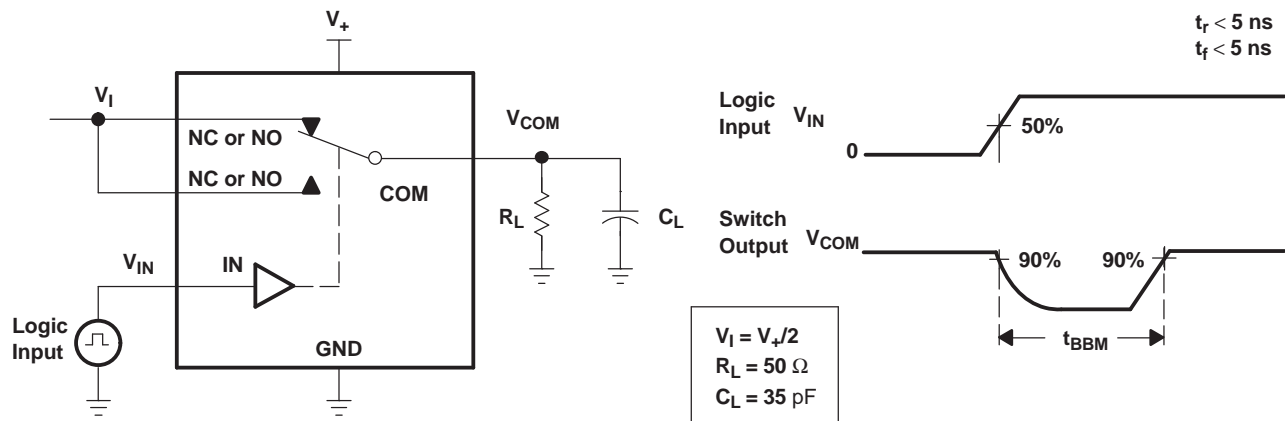

Figure 10. Break-Before-Make Time (t_{BBM})

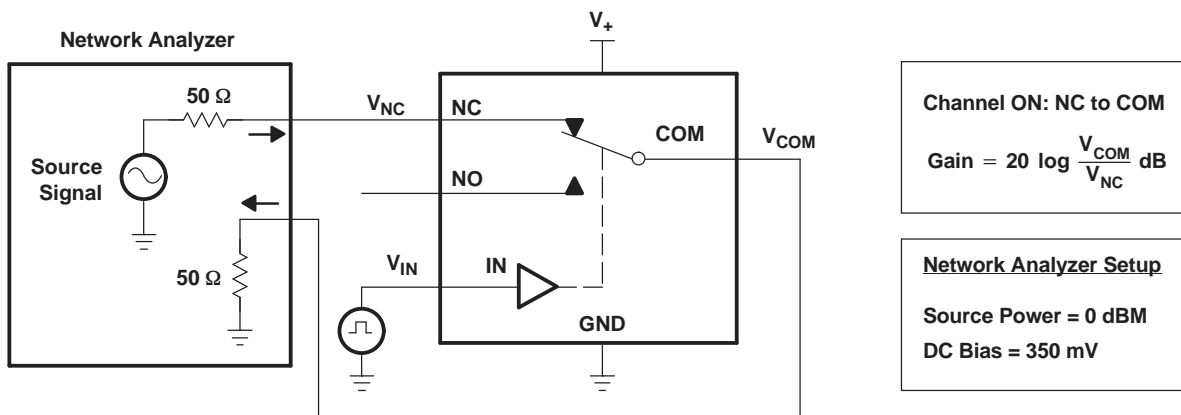

Figure 11. Frequency Response (BW)

PARAMETER MEASUREMENT INFORMATION (continued)

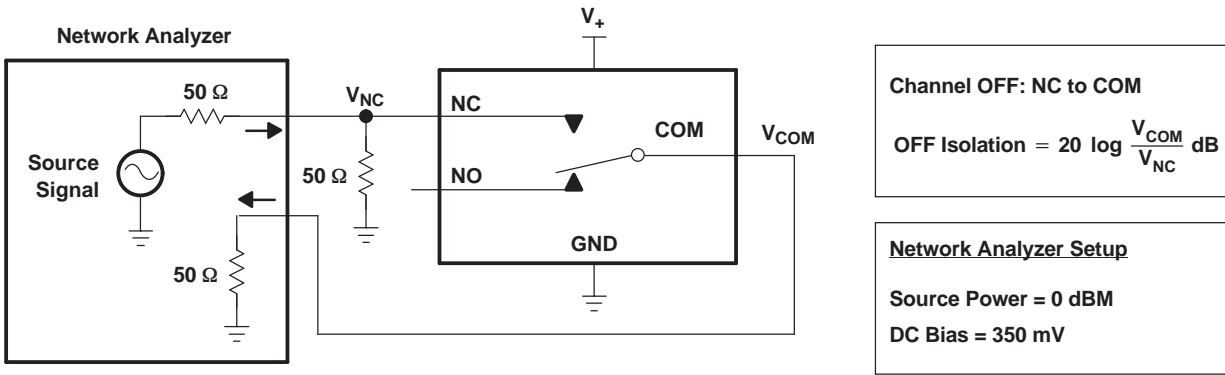

Figure 12. OFF Isolation (O_{ISO})

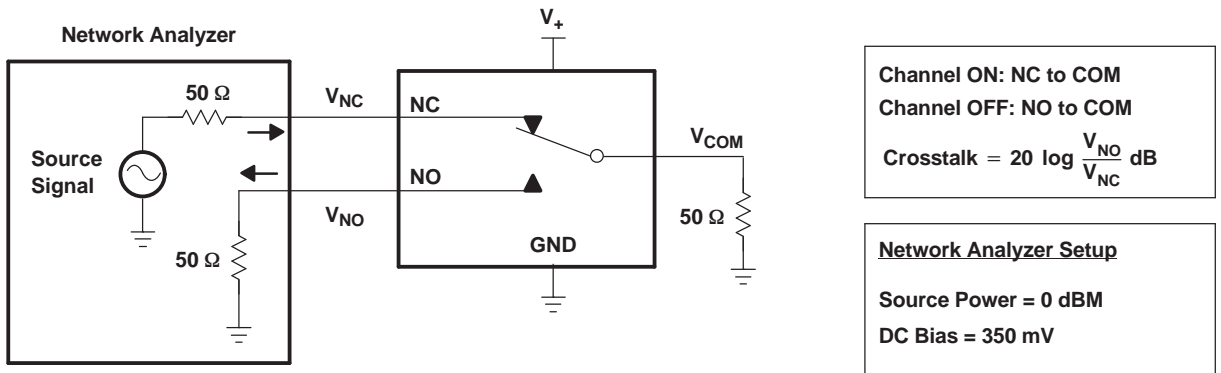

Figure 13. Crosstalk (X_{TALK})

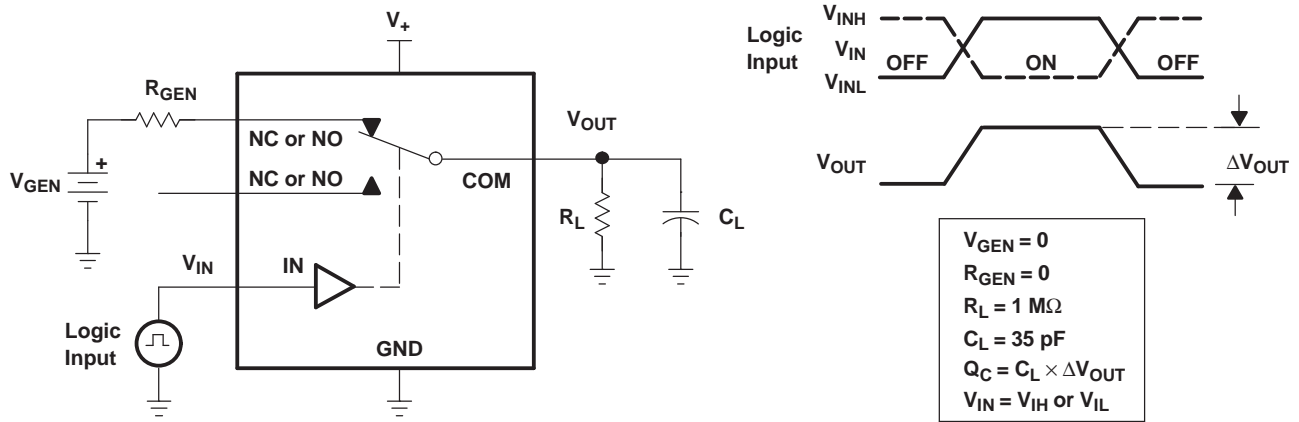

Figure 14. Charge Injection (Q_C)

PARAMETER MEASUREMENT INFORMATION (continued)

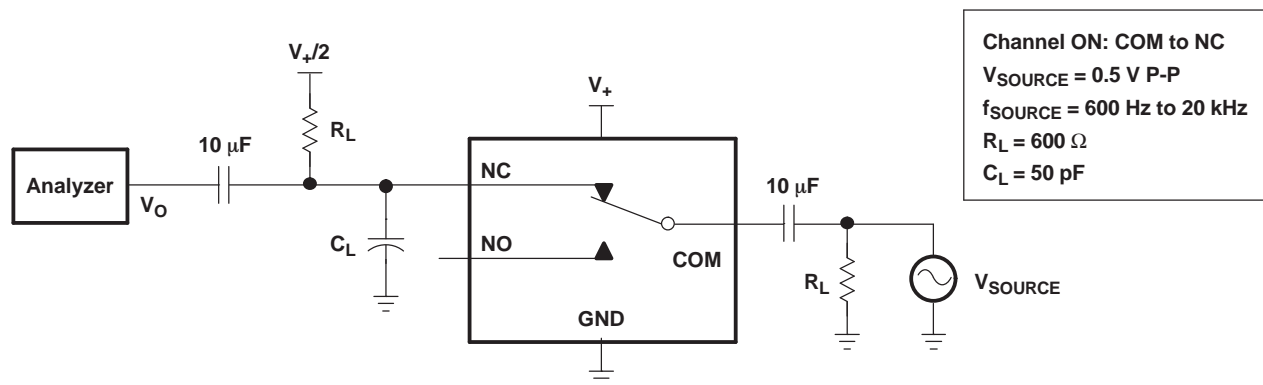

Figure 15. Total Harmonic Distortion (THD)

PACKAGING INFORMATION

Orderable Device	Status ⁽¹⁾	Package Type	Package Drawing	Pins	Package Qty	Eco Plan ⁽²⁾	Lead/Ball Finish	MSL Peak Temp ⁽³⁾
TS5A23157TDGSRQ1	ACTIVE	MSOP	DGS	10	2500	Green (RoHS & no Sb/Br)	CU NIPDAU	Level-1-260C-UNLIM

⁽¹⁾ The marketing status values are defined as follows:

ACTIVE: Product device recommended for new designs.

LIFEBUY: TI has announced that the device will be discontinued, and a lifetime-buy period is in effect.

NRND: Not recommended for new designs. Device is in production to support existing customers, but TI does not recommend using this part in a new design.

PREVIEW: Device has been announced but is not in production. Samples may or may not be available.

OBSOLETE: TI has discontinued the production of the device.

⁽²⁾ Eco Plan - The planned eco-friendly classification: Pb-Free (RoHS), Pb-Free (RoHS Exempt), or Green (RoHS & no Sb/Br) - please check <http://www.ti.com/productcontent> for the latest availability information and additional product content details.

TBD: The Pb-Free/Green conversion plan has not been defined.

Pb-Free (RoHS): TI's terms "Lead-Free" or "Pb-Free" mean semiconductor products that are compatible with the current RoHS requirements for all 6 substances, including the requirement that lead not exceed 0.1% by weight in homogeneous materials. Where designed to be soldered at high temperatures, TI Pb-Free products are suitable for use in specified lead-free processes.

Pb-Free (RoHS Exempt): This component has a RoHS exemption for either 1) lead-based flip-chip solder bumps used between the die and package, or 2) lead-based die adhesive used between the die and leadframe. The component is otherwise considered Pb-Free (RoHS compatible) as defined above.

Green (RoHS & no Sb/Br): TI defines "Green" to mean Pb-Free (RoHS compatible), and free of Bromine (Br) and Antimony (Sb) based flame retardants (Br or Sb do not exceed 0.1% by weight in homogeneous material)

⁽³⁾ MSL, Peak Temp. -- The Moisture Sensitivity Level rating according to the JEDEC industry standard classifications, and peak solder temperature.

Important Information and Disclaimer: The information provided on this page represents TI's knowledge and belief as of the date that it is provided. TI bases its knowledge and belief on information provided by third parties, and makes no representation or warranty as to the accuracy of such information. Efforts are underway to better integrate information from third parties. TI has taken and continues to take reasonable steps to provide representative and accurate information but may not have conducted destructive testing or chemical analysis on incoming materials and chemicals. TI and TI suppliers consider certain information to be proprietary, and thus CAS numbers and other limited information may not be available for release.

In no event shall TI's liability arising out of such information exceed the total purchase price of the TI part(s) at issue in this document sold by TI to Customer on an annual basis.

OTHER QUALIFIED VERSIONS OF TS5A23157-Q1 :

- Catalog: [TS5A23157](#)

NOTE: Qualified Version Definitions:

- Catalog - TI's standard catalog product

DGS (S-PDSO-G10)

PLASTIC SMALL-OUTLINE PACKAGE

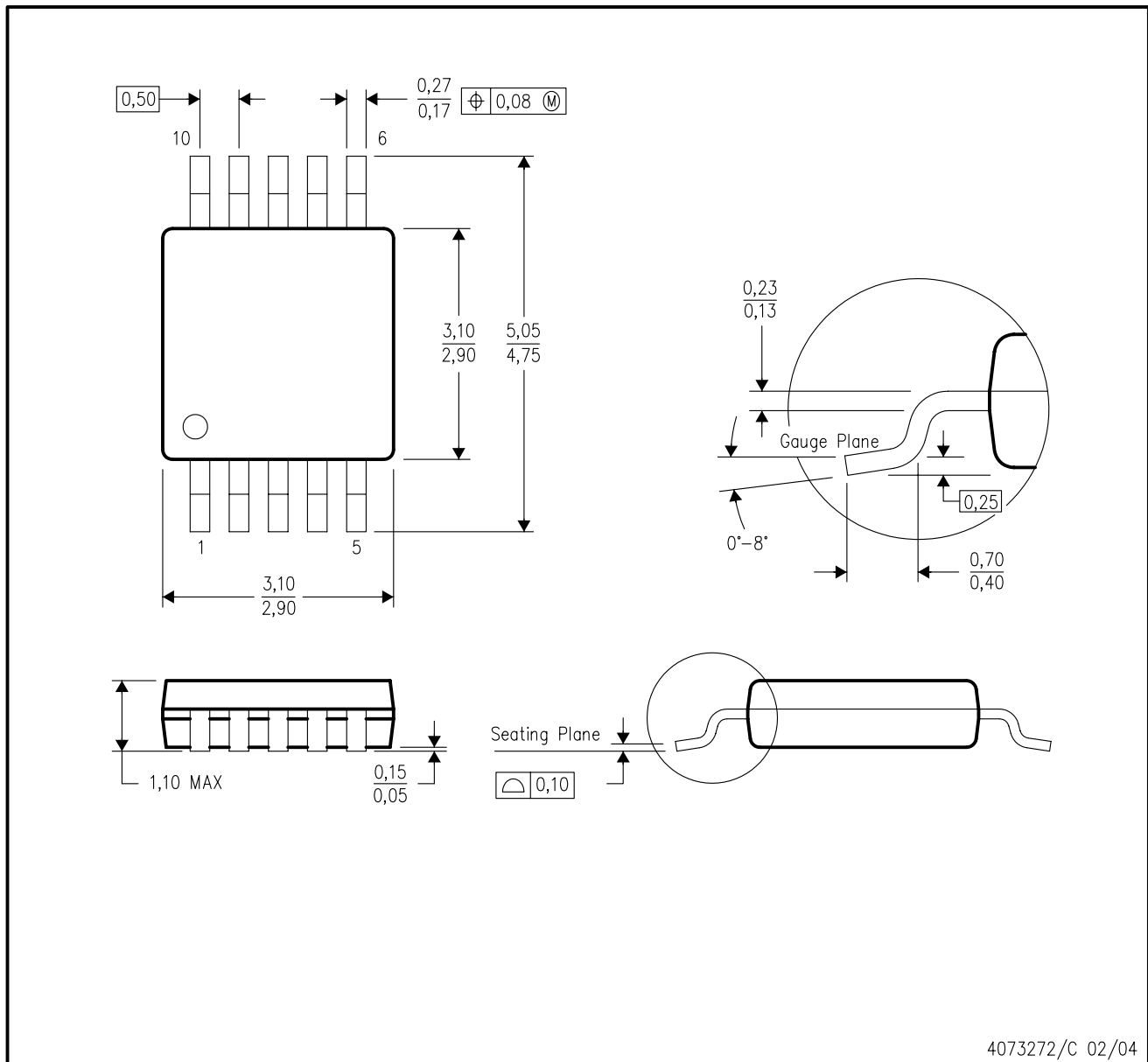

- NOTES:
- A. All linear dimensions are in millimeters.
 - B. This drawing is subject to change without notice.
 - C. Body dimensions do not include mold flash or protrusion.
 - D. Falls within JEDEC MO-187 variation BA.

IMPORTANT NOTICE

Texas Instruments Incorporated and its subsidiaries (TI) reserve the right to make corrections, modifications, enhancements, improvements, and other changes to its products and services at any time and to discontinue any product or service without notice. Customers should obtain the latest relevant information before placing orders and should verify that such information is current and complete. All products are sold subject to TI's terms and conditions of sale supplied at the time of order acknowledgment.

TI warrants performance of its hardware products to the specifications applicable at the time of sale in accordance with TI's standard warranty. Testing and other quality control techniques are used to the extent TI deems necessary to support this warranty. Except where mandated by government requirements, testing of all parameters of each product is not necessarily performed.

TI assumes no liability for applications assistance or customer product design. Customers are responsible for their products and applications using TI components. To minimize the risks associated with customer products and applications, customers should provide adequate design and operating safeguards.

TI does not warrant or represent that any license, either express or implied, is granted under any TI patent right, copyright, mask work right, or other TI intellectual property right relating to any combination, machine, or process in which TI products or services are used. Information published by TI regarding third-party products or services does not constitute a license from TI to use such products or services or a warranty or endorsement thereof. Use of such information may require a license from a third party under the patents or other intellectual property of the third party, or a license from TI under the patents or other intellectual property of TI.

Reproduction of TI information in TI data books or data sheets is permissible only if reproduction is without alteration and is accompanied by all associated warranties, conditions, limitations, and notices. Reproduction of this information with alteration is an unfair and deceptive business practice. TI is not responsible or liable for such altered documentation. Information of third parties may be subject to additional restrictions.

Resale of TI products or services with statements different from or beyond the parameters stated by TI for that product or service voids all express and any implied warranties for the associated TI product or service and is an unfair and deceptive business practice. TI is not responsible or liable for any such statements.

TI products are not authorized for use in safety-critical applications (such as life support) where a failure of the TI product would reasonably be expected to cause severe personal injury or death, unless officers of the parties have executed an agreement specifically governing such use. Buyers represent that they have all necessary expertise in the safety and regulatory ramifications of their applications, and acknowledge and agree that they are solely responsible for all legal, regulatory and safety-related requirements concerning their products and any use of TI products in such safety-critical applications, notwithstanding any applications-related information or support that may be provided by TI. Further, Buyers must fully indemnify TI and its representatives against any damages arising out of the use of TI products in such safety-critical applications.

TI products are neither designed nor intended for use in military/aerospace applications or environments unless the TI products are specifically designated by TI as military-grade or "enhanced plastic." Only products designated by TI as military-grade meet military specifications. Buyers acknowledge and agree that any such use of TI products which TI has not designated as military-grade is solely at the Buyer's risk, and that they are solely responsible for compliance with all legal and regulatory requirements in connection with such use.

TI products are neither designed nor intended for use in automotive applications or environments unless the specific TI products are designated by TI as compliant with ISO/TS 16949 requirements. Buyers acknowledge and agree that, if they use any non-designated products in automotive applications, TI will not be responsible for any failure to meet such requirements.

Following are URLs where you can obtain information on other Texas Instruments products and application solutions:

Products		Applications	
Amplifiers	amplifier.ti.com	Audio	www.ti.com/audio
Data Converters	dataconverter.ti.com	Automotive	www.ti.com/automotive
DLP® Products	www.dlp.com	Communications and Telecom	www.ti.com/communications
DSP	dsp.ti.com	Computers and Peripherals	www.ti.com/computers
Clocks and Timers	www.ti.com/clocks	Consumer Electronics	www.ti.com/consumer-apps
Interface	interface.ti.com	Energy	www.ti.com/energy
Logic	logic.ti.com	Industrial	www.ti.com/industrial
Power Mgmt	power.ti.com	Medical	www.ti.com/medical
Microcontrollers	microcontroller.ti.com	Security	www.ti.com/security
RFID	www.ti-rfid.com	Space, Avionics & Defense	www.ti.com/space-avionics-defense
RF/IF and ZigBee® Solutions	www.ti.com/lprf	Video and Imaging	www.ti.com/video
		Wireless	www.ti.com/wireless-apps

Mailing Address: Texas Instruments, Post Office Box 655303, Dallas, Texas 75265
Copyright © 2010, Texas Instruments Incorporated